

vanEE 40H+

Part no. 44252

37 to 71 CFM (0.4 in. w.g.)



VB0306

THE 40H+: PERFECTION IN A CUBE!

The 40H+ is the ideal choice for condominiums, apartments and other limited space applications that require up to 71 cfm of continuous ventilation. With its compact size and 4-inch vertical ports, it can be installed in small spaces such as a closet or mechanical room above a hot water tank.

The 40H+ has just one blower (patent pending) and is therefore quieter than any other similar HRV on the market.

- At just 30 lb. (13.6 kg), it can be installed without opening the unit
- Features pressure taps, balancing dampers, integrated hooks and port straps to simplify installation
- Removable terminal block for quicker wall control connections

REPAIRS AND MAINTENANCE

All parts of the 40H+ that could need maintenance can be removed in less than five minutes, allowing direct access for easy repairs. The PSC motor is permanently lubricated.

WARRANTY

The 40H+ is protected by a 5-year warranty on parts only. The heat recovery core is covered by a limited lifetime warranty, with the original proof of purchase.

Available at:



HEAT RECOVERY VENTILATOR

Controls

- This unit is very simple to operate. Once it is installed, press on its push button, located on the unit top left side, to select high speed, low speed or to stop it (the blower is off but will turn on in response to a wall control signal). The LED (located under the push button) will then show on which mode the unit is in.
- For more convenience, this unit can also be controlled by an optional main control. For a complete list of optional main and auxiliary controls available, refer to the **Wall Control Compatibility Chart** on last pages of wall controls specification sheet, available at www.vanee.ca.

For more details about controls, refer to their specification sheet and to the **Main and auxiliary wall control user guide** at www.vanee.ca.

Options

- Complete line of registers and diffusers
- Electrical duct heater
- Exclusive wall mounting bracket no. 19255

Defrosting System

The 40H+ uses a recirculation defrost method, which maintains balanced air pressure in the home. If there is a call for ventilation from an auxiliary wall control during the defrost cycle, the defrost is put "on hold" while air is exchanged, ensuring that no humid air is recirculated.

OUTSIDE TEMPERATURE		DEFROST CYCLE MIN./ OPERATING MIN.
°C	°F	
WARMER THAN -5	WARMER THAN 23	NO DEFROST
-5 TO -15	23 TO 5	5/30
-15 TO -27	5 TO -17	5/20
-27 AND LESS	-17 AND LESS	7/15

Heat Recovery Core

Dimensions: 10" x 10" x 5.5" (25.4 cm x 25.4 cm x 14 cm)

Exchange surface: 42.3 ft.² (3.9 m²)

Weight: 4 lb. (1.8 kg)

Material: Polypropylene

Type: Cross flow

Warranty: Limited lifetime

Requirements and standards

- Complies with the UL 1812 requirements regulating the installation of Heat Recovery Ventilators
- Complies with the CSA C22.2 no. 113 Standard applicable to ventilators
- Complies with CSA F326 requirements regulating the installation of Heat Recovery Ventilators
- Technical data was obtained from published results of tests relating to CSA C439 Standards
- HVI certified

VENTILATION PERFORMANCE

EXTERNAL STATIC PRESSURE		NET SUPPLY AIR FLOW			GROSS AIR FLOW					
					SUPPLY			EXHAUST		
PA	IN. W.G.	L/S	CFM	M ³ /H	L/S	CFM	M ³ /H	L/S	CFM	M ³ /H
25	0.1	39	82	139	40	84	143	43	92	156
50	0.2	37	79	134	38	81	138	41	87	148
75	0.3	35	75	127	37	77	131	39	83	141
100	0.4	34	71	121	35	73	124	37	78	133
125	0.5	32	67	114	33	69	117	35	73	124
150	0.6	30	63	107	31	65	110	32	68	116
175	0.7	28	59	100	29	61	104	30	63	107
200	0.8	27	56	95	27	58	99	27	58	99

ENERGY PERFORMANCE

SUPPLY TEMPERATURE		NET AIR FLOW			POWER CONSUMED WATTS	SENSIBLE RECOVERY EFFICIENCY	ADJUSTED SENSIBLE RECOVERY EFFICIENCY	APPARENT SENSIBLE EFFECTIVENESS*	LATENT RECOVERY/MOISTURE TRANSFER
°C	°F	L/S	CFM	M ³ /H					
HEATING									
0	32	22	47	80	39	66	71	76	0
0	32	29	62	105	48	63	68	72	0
-25	-13	23	48	82	49	60	63	78	0.04
-25	-13	30	64	109	63	55	59	70	0.05

*Data not certified by HVI.

NOTE: All specifications are subject to change without notice.

SPECIFICATIONS

- Model: 40H+
- Part Number: 44252
- Total Assembled Weight (including polypropylene core): 30 lb. (13.6 kg)
- Round 4" ports
- Drain: 1/2" (1.2 cm) fitting with 10 ft. (3 m) PVC drain hose
- Core Filters: 2 washable foam filters, 30 ppi 9.2" x 5.75" x 0.38" (23.4 cm x 16.6 cm x 1 cm)
- Housing: Pre-painted steel
- Insulation: Expanded polystyrene
- Mounting: Suspension by chains and spring or optional wall bracket
- Supply and Exhaust Blower Motor: 1 motor
 - Protection type: Thermally protected
 - Insulation class: B
- Speed Control on Unit:
 - Low speed and high speed
 - Other modes available with optional wall controls
- Heat Recovery Core:
 - Heat Exchange Surface Area: 42.3 ft.² (3.9 m²)
 - Type: Crossflow
 - Material: Polypropylene
- Unit Electrical Characteristics:

Volts	Frequency	Ampere	Watts
120	60 Hz	0.5	60

DIMENSIONS: 40H+

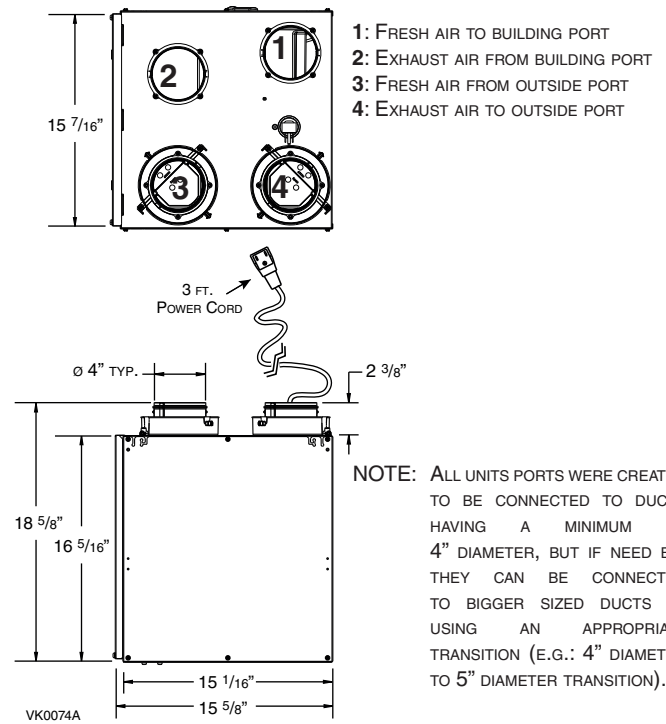

Project:	REMARKS
Location:	
Part no.:	
Qty.:	
Submitted by:	Date:



Venmar Ventilation ULC, 550 Lemire Blvd., Drummondville, Québec, Canada J2C 7W9 vanee.ca 800-567-3855



40H+d211116